

PARTS LIST				
ITEM	QTY	PART NUMBER	MATERIAL	DESCRIPTION
1	1	BASE	GENERIC	
2	1	SLIDING JAW	GENERIC	
3	3	JAW PLATE	SAE3140	
4	1	WISE SKREW	SAE3140	
5	1	COLLAR	SAE1020	
6	1	SPECIAL KEY	SAE1020	
7	1	HANDLE ROD	GENERIC	
8	2	HANDLE BALL	SAE1020	
11	2	SET SCREW	Generic	
12	2	SLIDE KEY	Generic	
13	6	SLOTTED FLAT COUNTERSUNK HEAD CAP SCREW	STEEL,MILD	ANSI B18.6.2 - 1/4-20 UNC x 0.625
14	2	TAPER PIN	TYPICAL	#000

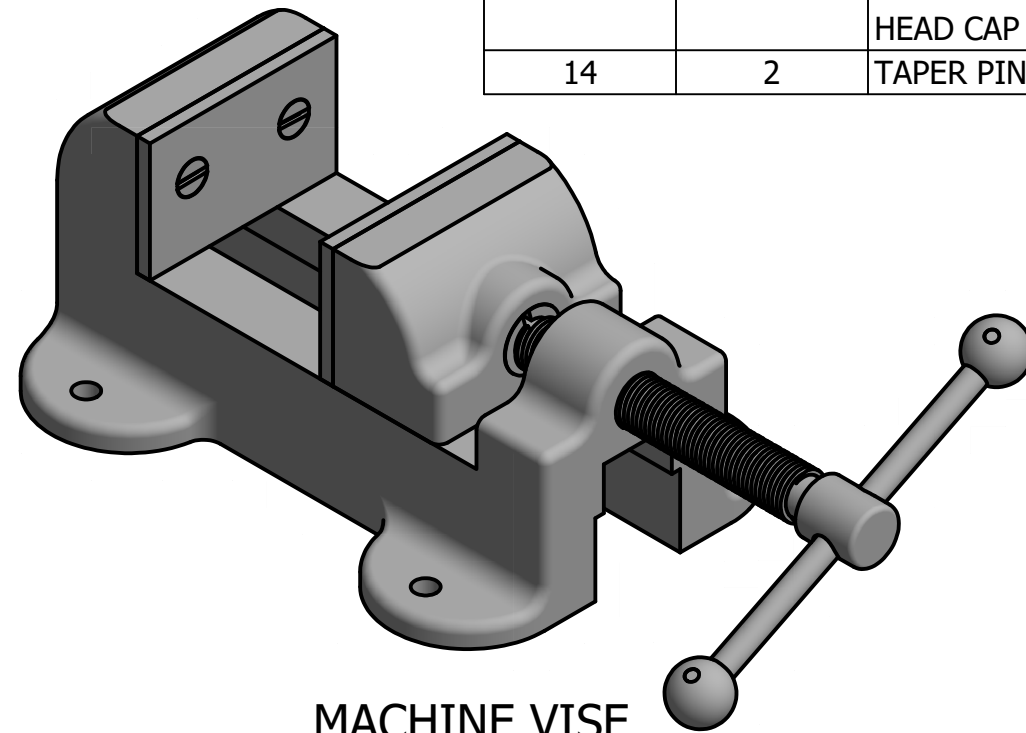

MACHINE VISE
SCALE 1 / 2

LEGEND:

- ∅ DIAMETER
- R RADIUS
- ° DEGREES
- COUNTERBORE
- ∇ DEPTH

GENERAL NOTES:

FILLETS AND ROUNDS 1/8R UNLESS OTHERWISE SPECIFIED



DIGITAL DESIGN
GRAPHICS
TECHNOLOGY

WWW.DDGT.NET



Jose Lara
Drafting & Design

707-501-8836
joselara218@yahoo.com

www.ddgt.net/Student_Pages/jlara

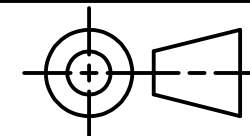

TOLERANCES UNLESS SPECIFIED:
DECIMAL INCHES:
X = ±.020
XX = ±.010
XXX = ±.005
FRACTIONAL ±1/64"
ANGLES ± DEGREE
SURFACES 32 ✓

COURSE: DDGT 240

INVENTOR DRAWING NAME:
MACHINE VISE

FIG #: 14-71

DRAFTER: JLARA

DATE: 9/26/2018

SCALE: AS NOTED

PAGE #: 1 OF 6

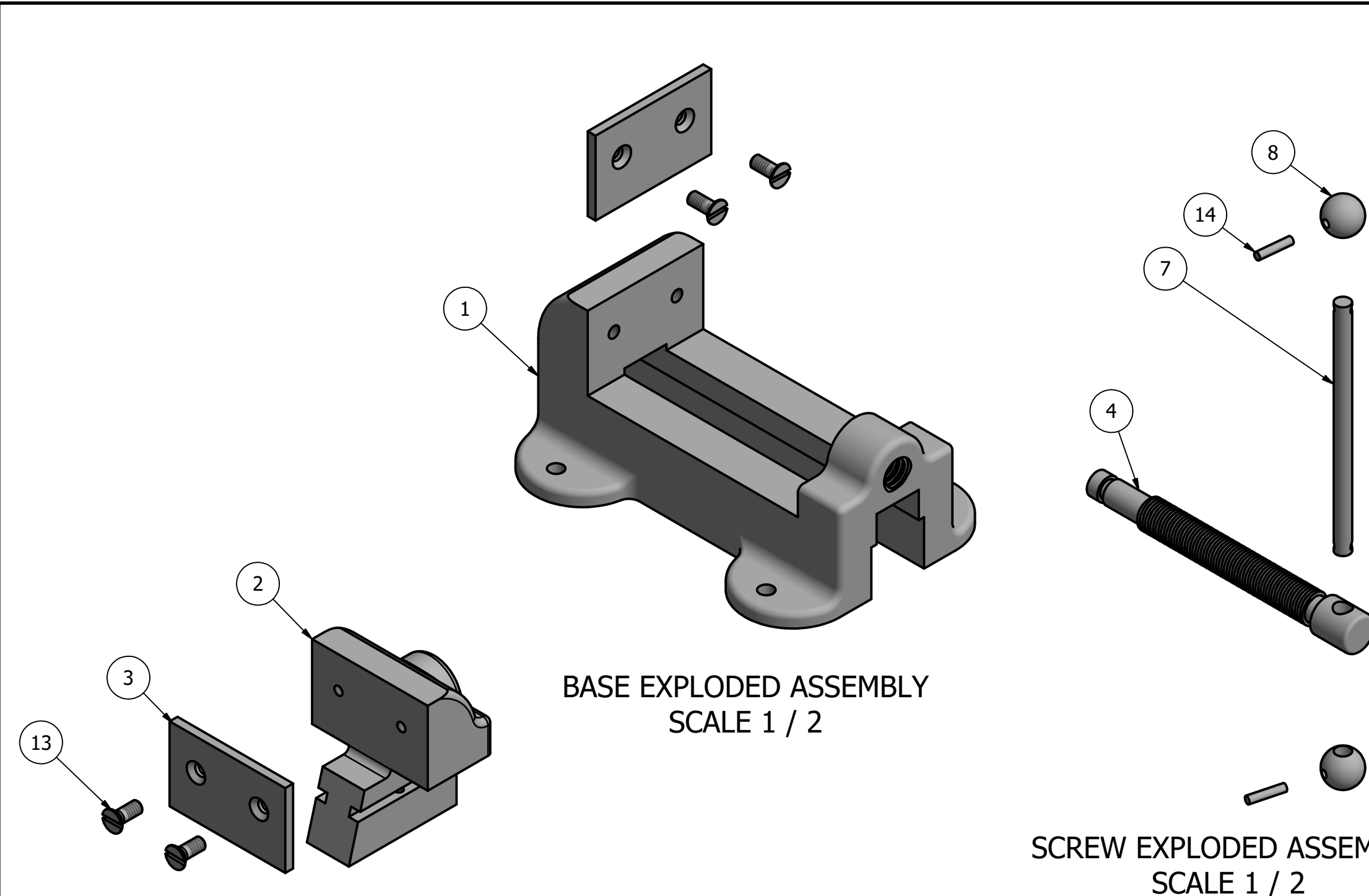

BASE EXPLODED ASSEMBLY
SCALE 1 / 2

SCREW EXPLODED ASSEMBLY
SCALE 1 / 2

JAW EXPLODED ASSEMBLY
SCALE 1 / 2

PARTS LIST		
ITEM	QTY	PART NUMBER
1	1	BASE
2	1	SLIDING JAW
3	3	JAW PLATE
4	1	WISE SKREW
7	1	HANDLE ROD
8	2	HANDLE BALL
13	6	SLOTTED FLAT COUNTERSUNK HEAD CAP SCREW
14	2	TAPER PIN

LEGEND:

- ∅ DIAMETER
- R RADIUS
- ° DEGREES
- COUNTERBORE
- ▽ DEPTH

 DIGITAL DESIGN GRAPHICS TECHNOLOGY WWW.DDGT.NET	 Jose Lara Drafting & Design 707-501-8836 joselara218@yahoo.com www.ddgt.net/Student_Pages/jlara	 TOLERANCES UNLESS SPECIFIED: DECIMAL INCHES: X = ±.020 XX = ±.010 XXX = ±.005 FRACTIONAL ±1/64" ANGLES ± DEGREE SURFACES 32 ✓	COURSE: DDGT 240
			INVENTOR DRAWING NAME: MACHINE VISE
			FIG #: 14-71
			DRAFTER: JLARA
			DATE: 9/26/2018
			SCALE: AS NOTED
			PAGE #: 2 OF 6

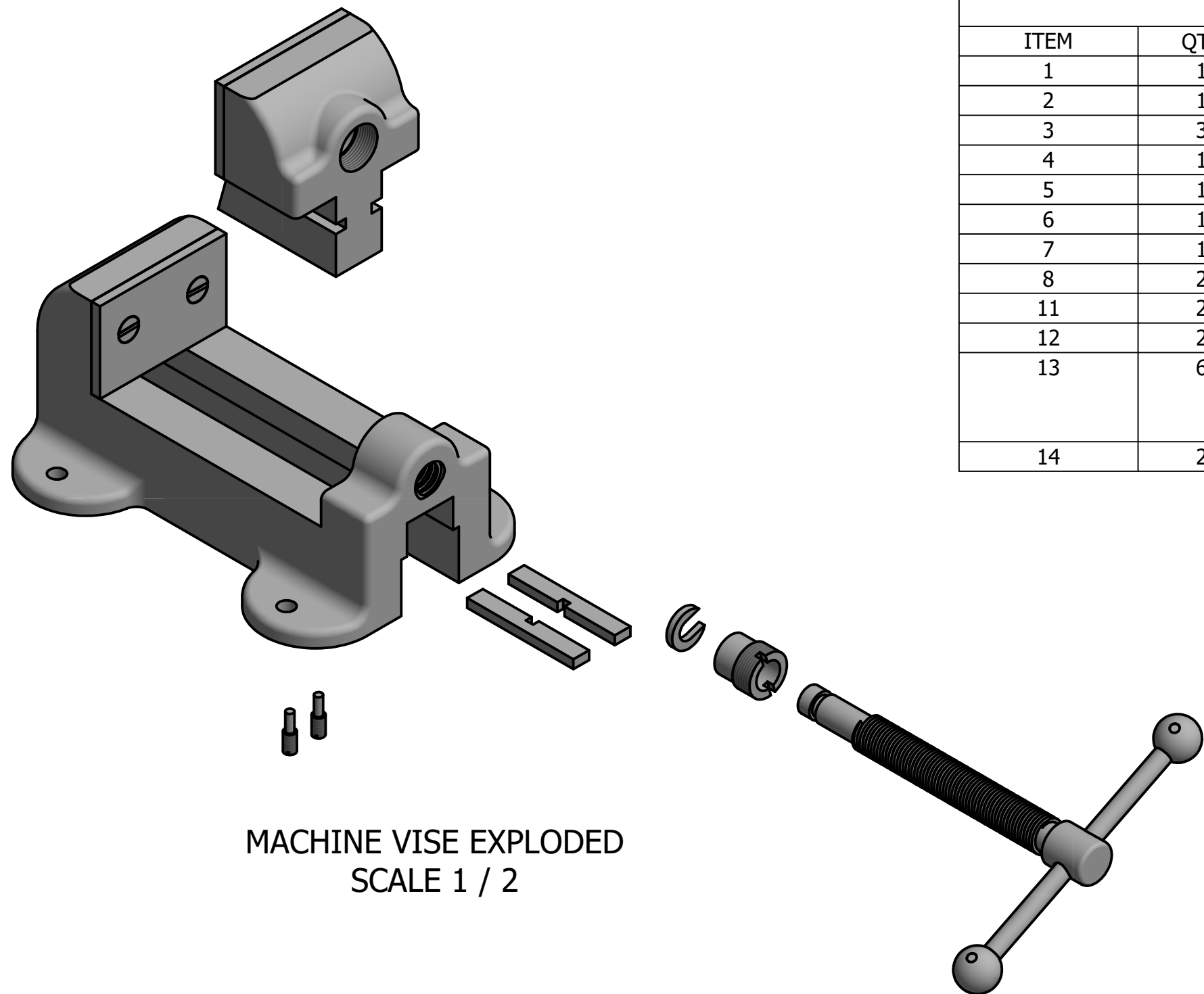

MACHINE VISE EXPLODED
SCALE 1 / 2

PARTS LIST			
ITEM	QTY	PART NUMBER	DESCRIPTION
1	1	BASE	
2	1	SLIDING JAW	
3	3	JAW PLATE	
4	1	WISE SKREW	
5	1	COLLAR	
6	1	SPECIAL KEY	
7	1	HANDLE ROD	
8	2	HANDLE BALL	
11	2	SET SCREW	
12	2	SLIDE KEY	
13	6	SLOTTED FLAT COUNTERSUNK HEAD CAP SCREW	ANSI B18.6.2 - 1/4-20 UNC x 0.625
14	2	TAPER PIN	#000

LEGEND:

- ∅ DIAMETER
- R RADIUS
- ° DEGREES
- ┌┐ COUNTERBORE
- ▽ DEPTH



DIGITAL DESIGN
GRAPHICS
TECHNOLOGY

WWW.DDGT.NET



Jose Lara
Drafting & Design

707-501-8836
joselara218@yahoo.com

www.ddgt.net/Student_Pages/jlara

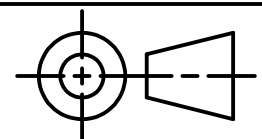

TOLERANCES UNLESS SPECIFIED:
DECIMAL INCHES:
X = ±.020
XX = ±.010
XXX = ±.005
FRACTIONAL ±1/64"
ANGLES ± DEGREE
SURFACES 32 ✓

COURSE: DDGT 240

INVENTOR DRAWING NAME:
MACHINE VISE

FIG #: 14-71

DRAFTER: JLARA

DATE: 9/26/2018

SCALE: AS NOTED

PAGE #: 3 OF 6

PARTS LIST		
ITEM	QTY	PART NUMBER
1	1	BASE
3	3	JAW PLATE

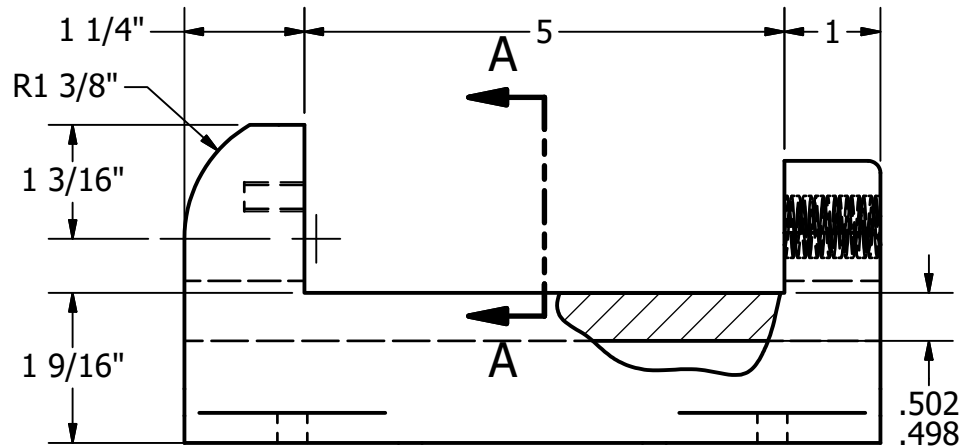
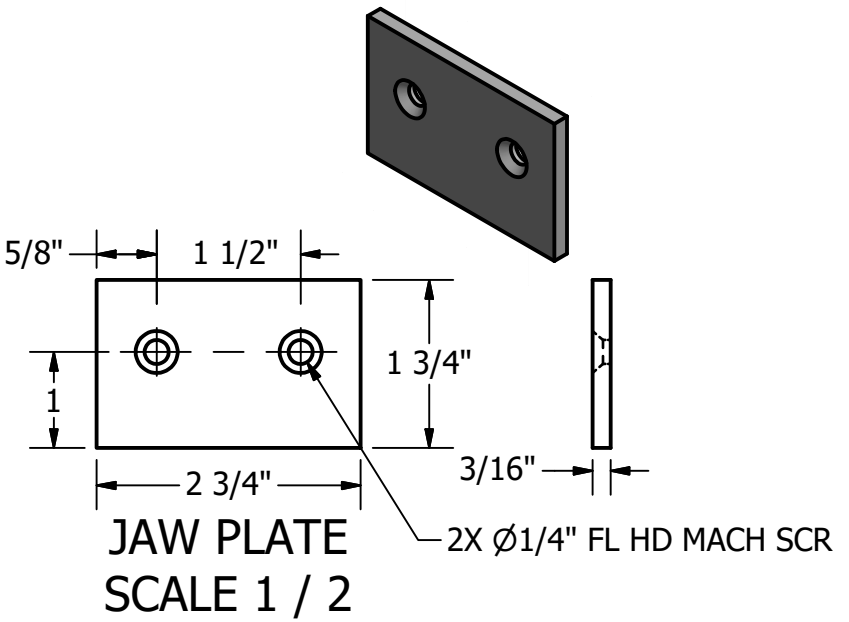
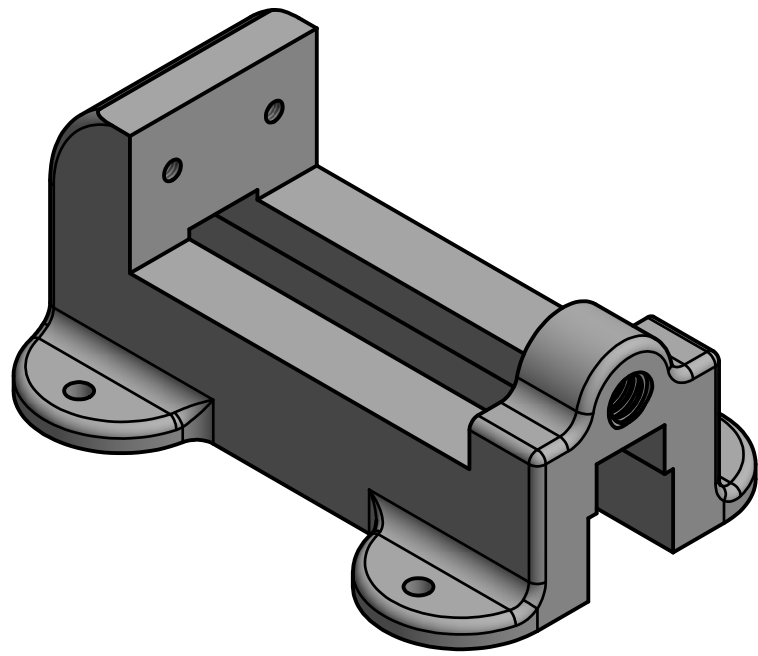
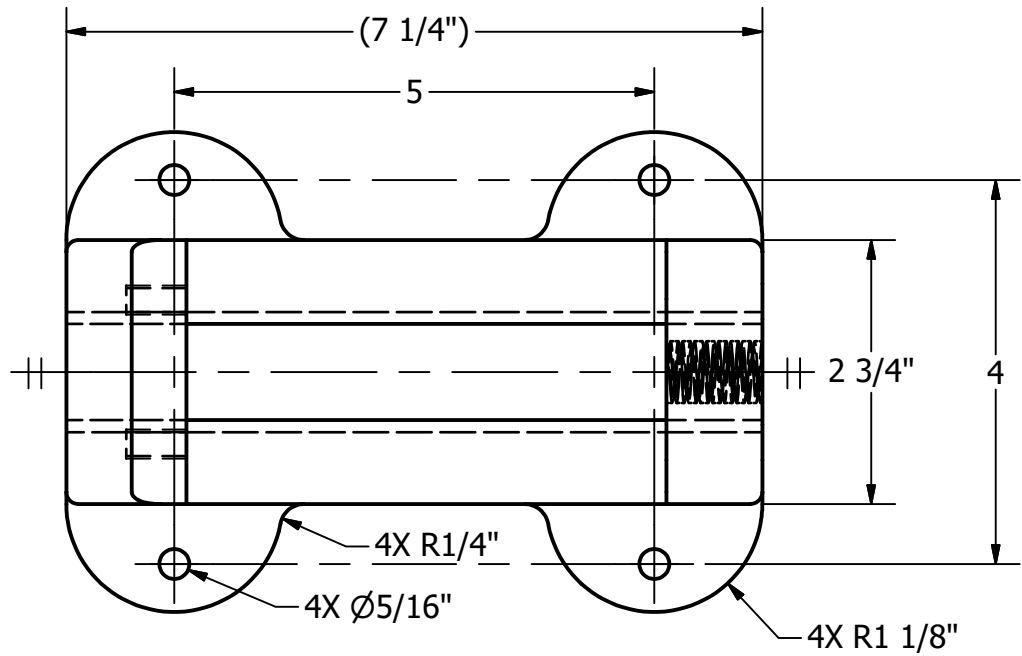

BASE
SCALE 1 / 2

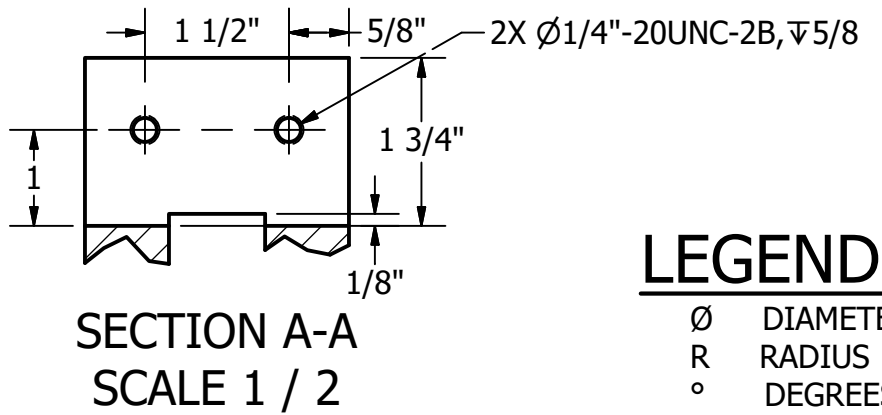
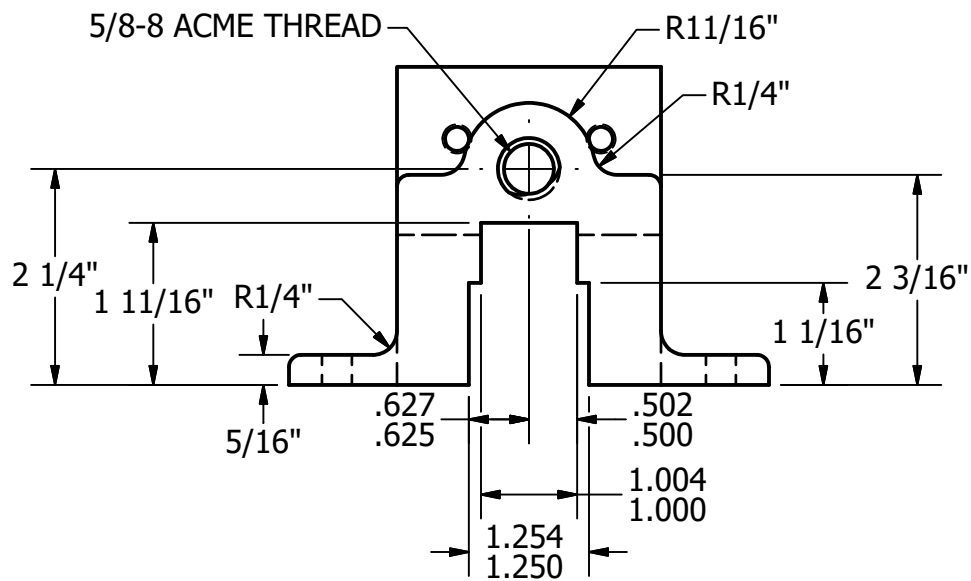

LEGEND:

- Ø DIAMETER
- R RADIUS
- ° DEGREES
- COUNTERBORE
- ∇ DEPTH



DIGITAL DESIGN
GRAPHICS
TECHNOLOGY

WWW.DDGT.NET

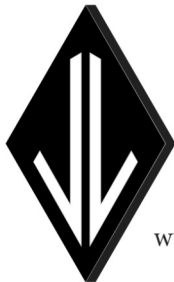

Jose Lara
Drafting & Design

707-501-8836
joselara218@yahoo.com

www.ddgt.net/Student_Pages/jlara

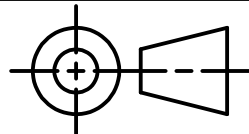

TOLERANCES UNLESS SPECIFIED:
DECIMAL INCHES:
X = ±.020
XX = ±.010
XXX = ±.005
FRACTIONAL ±1/64"
ANGLES ± DEGREE
SURFACES 32 ✓

COURSE: DDGT 240

INVENTOR DRAWING NAME:
MACHINE VISE

FIG #: 14-71

DRAFTER: JLARA

DATE: 9/26/2018

SCALE: AS NOTED

PAGE #: 4 OF 6

PARTS LIST		
ITEM	QTY	PART NUMBER
2	1	SLIDING JAW
6	1	SPECIAL KEY
7	1	HANDLE ROD
8	2	HANDLE BALL

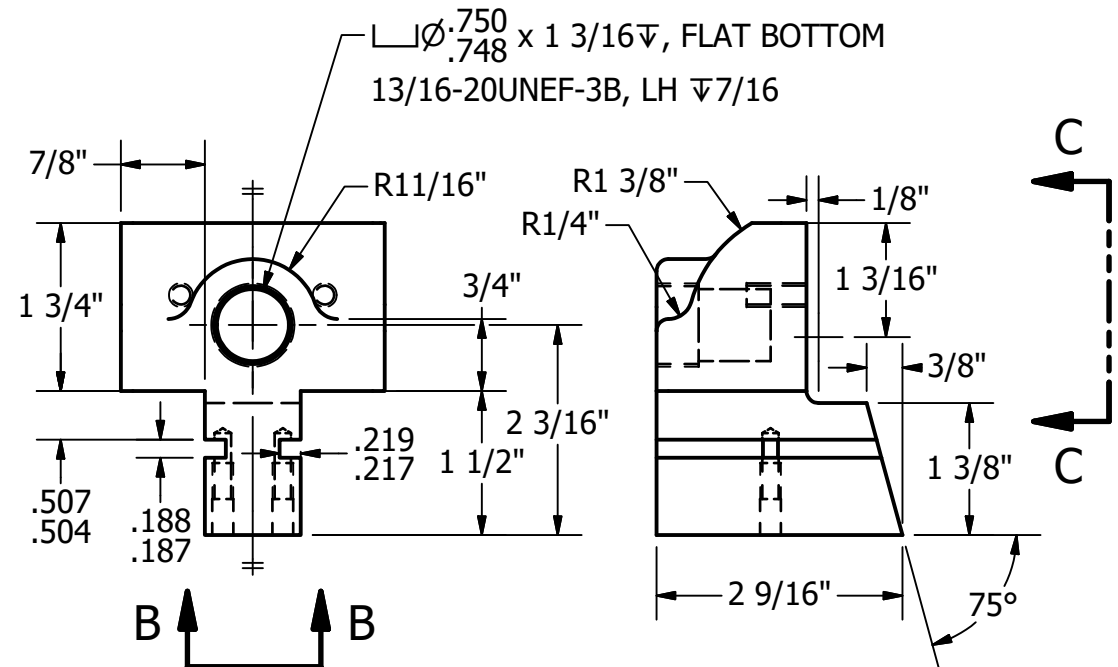

B ↑ ↑ **B**
SLIDING JAW
SCALE 1 / 2

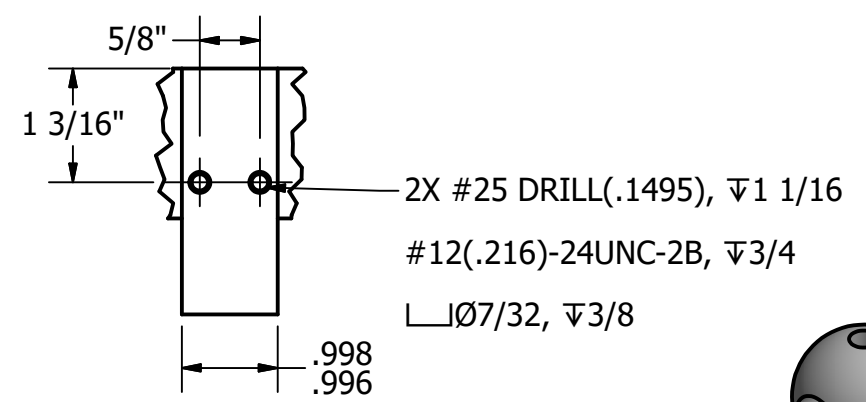
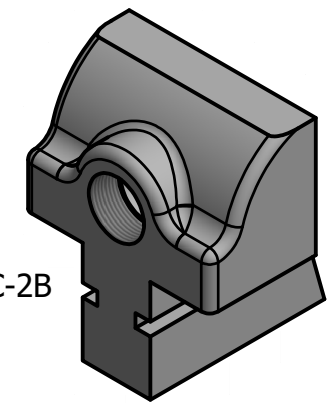
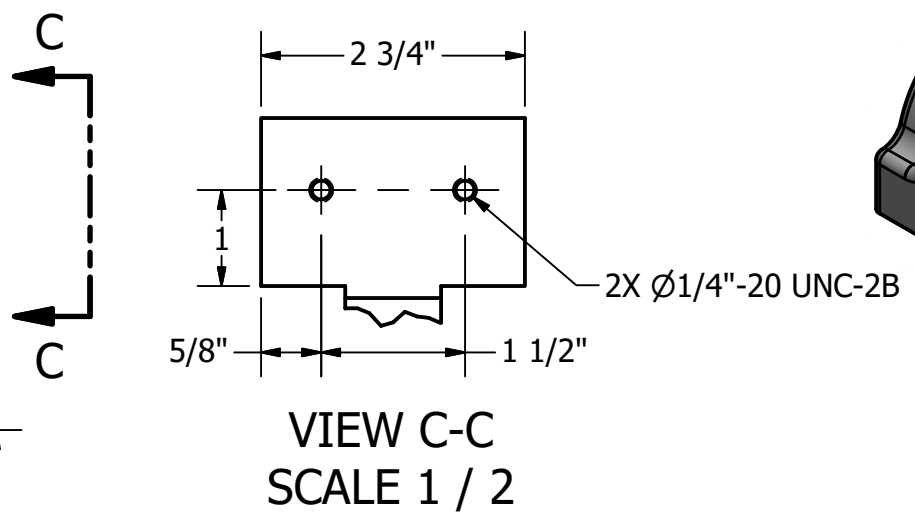

VIEW B-B
SCALE 1 / 2

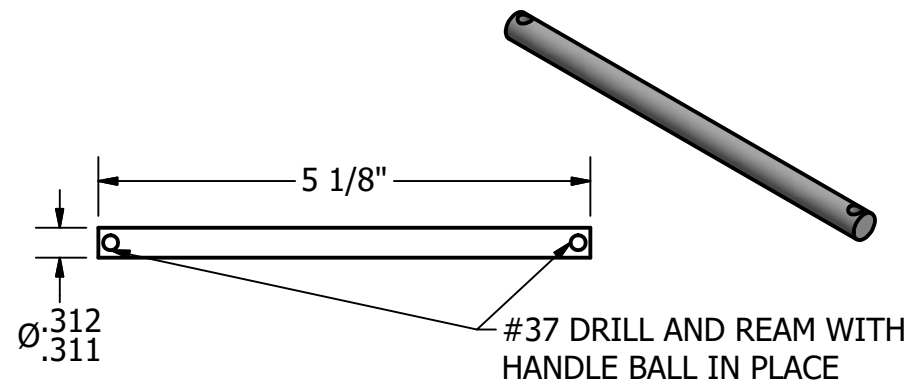

HANDLE ROD
SCALE 1 / 2

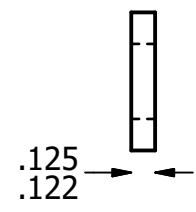
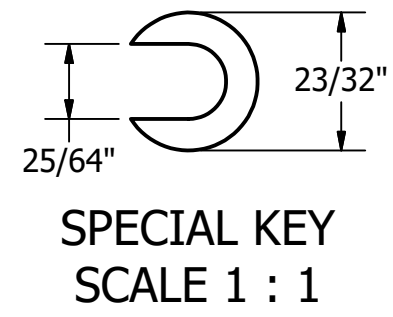

LEGEND:

- \varnothing DIAMETER
- R RADIUS
- ° DEGREES
- \square COUNTERBORE
- ∇ DEPTH

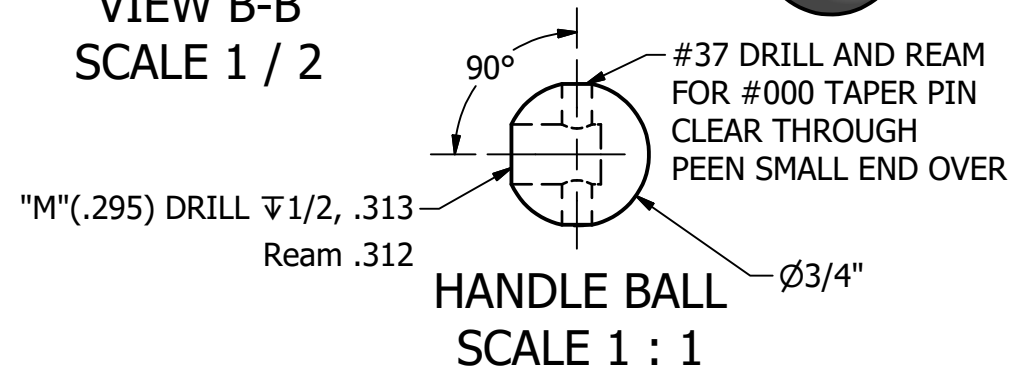

DDGT
 DIGITAL DESIGN
 GRAPHICS
 TECHNOLOGY
 WWW.DDGT.NET



Jose Lara
 Drafting & Design
 707-501-8836
 joselara218@yahoo.com
 www.ddgt.net/Student_Pages/jlara

TOLERANCES UNLESS SPECIFIED:
 DECIMAL INCHES:
 X = ±.020
 XX = ±.010
 XXX = ±.005
 FRACTIONAL ±1/64"
 ANGLES ± DEGREE
 SURFACES 32 ✓

COURSE:	DDGT 240
INVENTOR DRAWING NAME:	MACHINE VISE
FIG #:	14-71
DRAFTER:	JLARA
DATE:	9/26/2018
SCALE:	AS NOTED
PAGE #:	5 OF 6

PARTS LIST		
ITEM	QTY	PART NUMBER
4	1	WISE SKREW
5	1	COLLAR
11	2	SET SCREW
12	2	SLIDE KEY

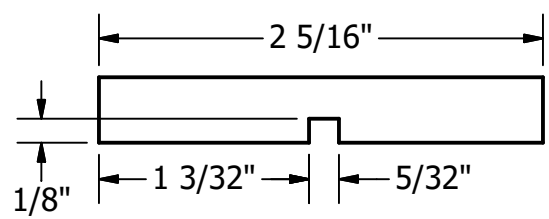
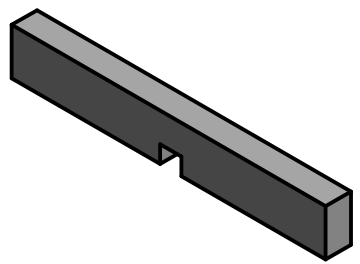

SLIDE KEY
SCALE 1 : 1

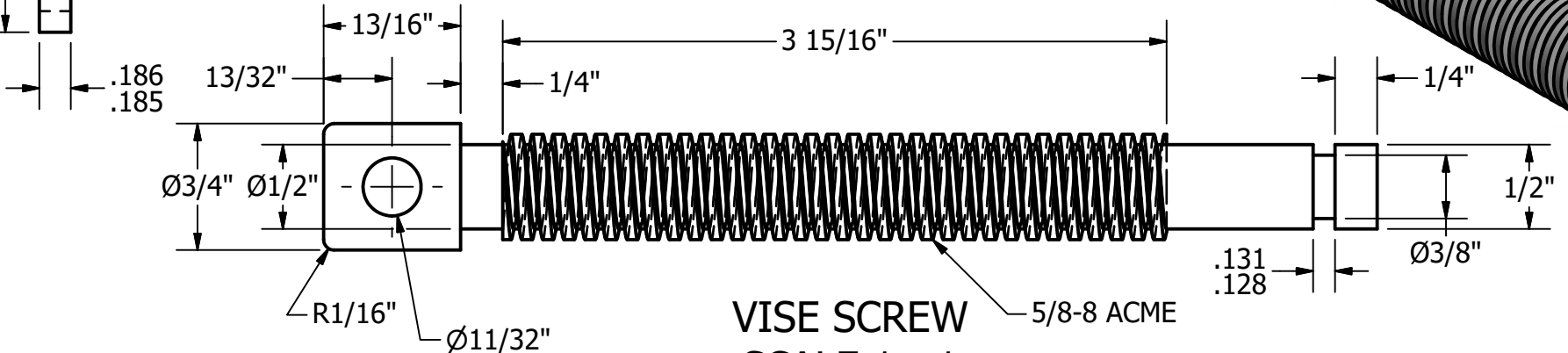
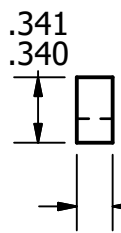

WISE SCREW
SCALE 1 : 1

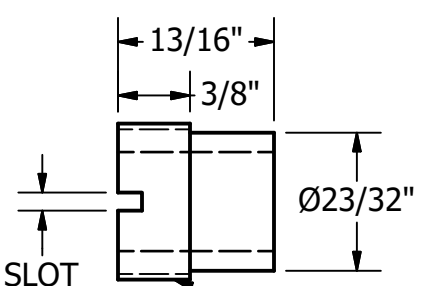
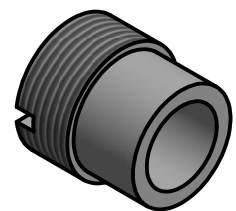
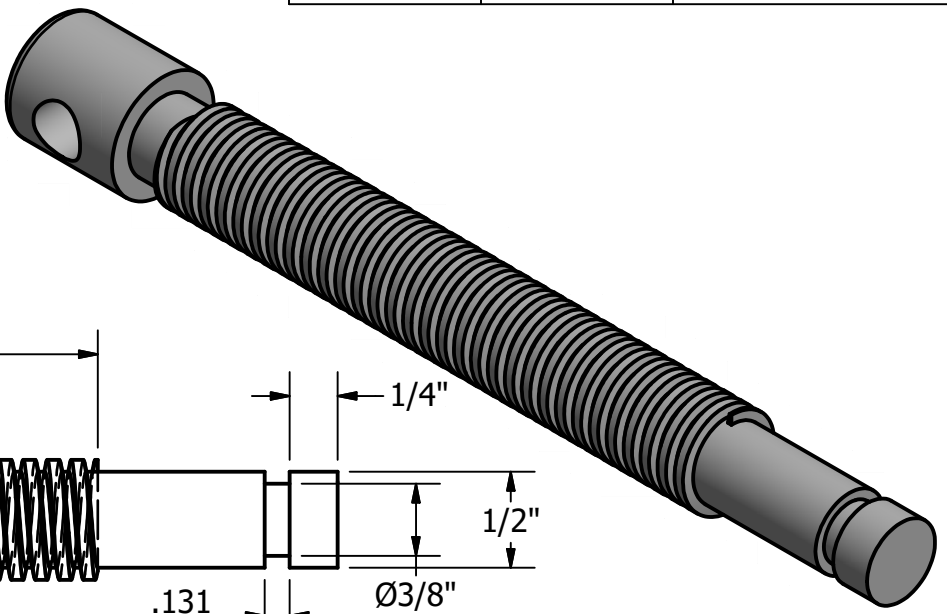

COLLAR
SCALE 1 : 1

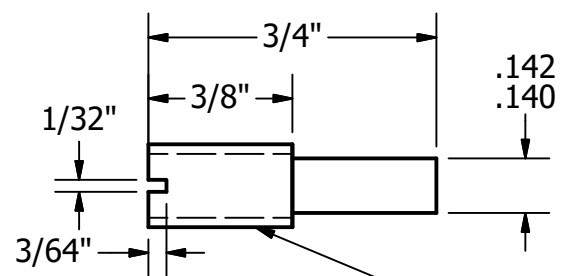
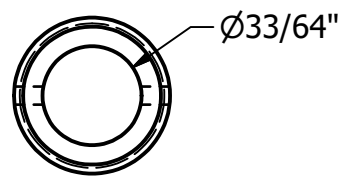

SET SCREW
SCALE 2 : 1

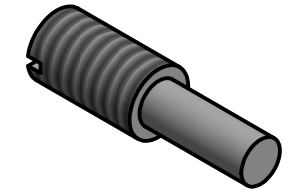

LEGEND:

- Ø DIAMETER
- R RADIUS
- ° DEGREES
- COUNTERBORE
- ∇ DEPTH

3/32" x ∇1/8" SLOT

<p>DIGITAL DESIGN GRAPHICS TECHNOLOGY</p> <p>WWW.DDGT.NET</p>	<p>Jose Lara Drafting & Design</p> <p>707-501-8836 joselara218@yahoo.com</p> <p>www.ddgt.net/Student_Pages/jlara</p>	<p>TOLERANCES UNLESS SPECIFIED: DECIMAL INCHES: X = ±.020 XX = ±.010 XXX = ±.005 FRACTIONAL ±1/64" ANGLES ± DEGREE SURFACES 32 ✓</p>	COURSE: DDGT 240
			INVENTOR DRAWING NAME: MACHINE VISE
			FIG #: 14-71
			DRAFTER: JLARA
			DATE: 9/26/2018
			SCALE: AS NOTED
			PAGE #: 6 OF 6